

**DISPLAYING ROOM TEMPERATURE**

If the P5 parameter is set to display the temperature set point, the probe temperature can be displayed by pressing the DOWN ARROW key for two seconds until Pb1 is displayed. Next, hit the SET key. To return to the normal display, press SET key.

**MANUAL DEFROST ACTIVATION/DEACTIVATION**

To manually activate the defrost cycle, press the UP ARROW key for four seconds. This feature is disabled during heating operation.

**PARAMETER LOCK OUT ACTIVATION/DEACTIVATION**

The key pad lock out can be activated/deactivated by pressing the SET and DOWN ARROW keys simultaneously for two seconds. The display will flash Loc or UnL to signify the change in states.

**ALARM BUZZER RESET**



The audible alarm can be silenced by pressing any key.

**RESTORING FACTORY DEFAULT SETTINGS**

Factory settings can be restored by following the below procedure:

- Pressing the UP ARROW and DOWN ARROW keys for four seconds until PA is displayed
- Press the SET key
- Press the UP ARROW or DOWN ARROW to adjust the value to 743
- Press SET key
- Pressing the UP ARROW and DOWN ARROW keys for four seconds until dEF is displayed
- Press SET key
- Press the UP ARROW or DOWN ARROW to adjust the value to 149
- Press SET key
- Cycle the power after the flashing dEF goes away

**DISPLAY MESSAGES**

Out 1 solidly lit	Output 1 is active
Out 1 flashing	Either modification of set point or call for load during load protection (C1 or C2)
	Defrost cycle is active
	Alarm condition is present
°C	Temperature is measured in °C
°F	Temperature is measured in °F
Loc	Key pad is locked
Pr1	Probe 1 error

**MAINTENANCE, CLEANING AND REPAIR**

After final installation of the unit no routine maintenance is required. Clean the surface of the display controller with a soft and damp cloth. Never use abrasive detergents, petrol, alcohol or solvents. A periodic check of the system calibration is recommended. The Series 40T is not field serviceable and should be returned if repair is needed (field repair should not be attempted and may void warranty). Be sure to include a brief description of the problem plus any relevant application notes. Contact customer service to receive a return goods authorization number before shipping.

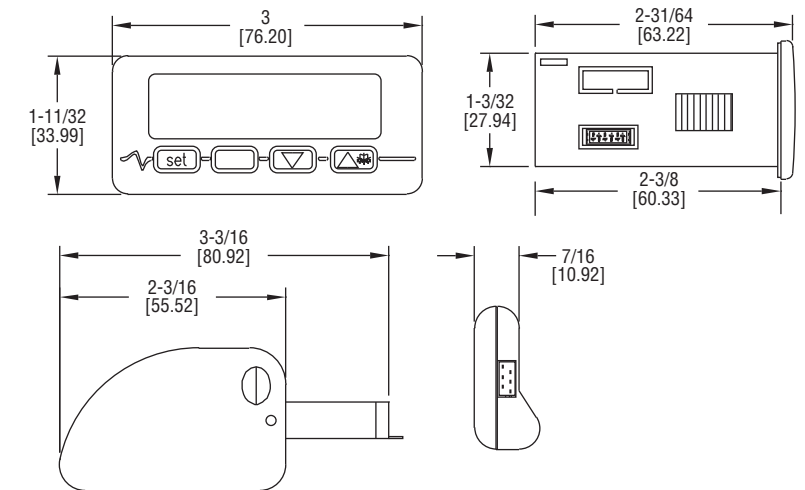
**Series 40T Digital Thermocouple/RTD Temperature Switch****Specifications - Installation and Operating Instructions**

The Series 40T Digital Temperature Switch accepts thermocouple and RTD inputs to allow temperature measurements and set points up to 1999°F (1300°C). Observing the current status of the control is made easier with the 3-1/2 digit, multi-color LED display that has alarm, defrost and output symbols. For added versatility, the temperature units can be field selected for °F or °C. For cooling applications, manual defrost mode can be initiated by pushing a single button. A flashing alarm informs users when the current temperature exceeds preset limits. When programming multiple units, a programming key is available to reduce set up time.

**INSTALLATION**

**Note: Unit must be mounted away from vibration, impacts, water and corrosive gases.**

- Cut hole in panel 71 x 29 mm (2.80 x 1.14 in)
- Apply silicone around the perimeter of the hole to prevent leakage
- Insert unit into hole from the front side of the panel
- Slide the mounting bracket securely against the panel from the rear of the unit
- Wiring diagram is displayed on top of the control

**WIRING**

Avoid installing the temperature probe cables in close proximity of any power cables. If the length of the probe cables is longer than 100 meters, a recalibration adjustment may be made using the CA1 parameter.

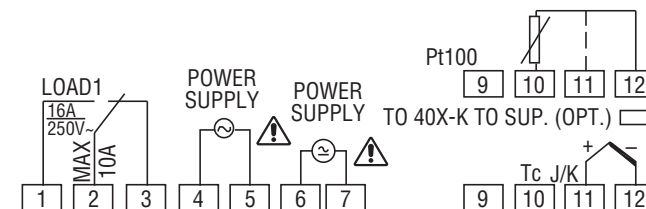

**Note:** Terminals 4 and 5 are only on 115 VAC and 230 VAC. Models 12 to 24 VAC only have terminals 6 and 7.

**SPECIFICATIONS**

**Probe Range:** K T/C: -140 to 1999°F (-100 to 1300°C);  
J T/C: -140 to 1450°F (-100 to 800°C);  
RTD: -320 to 1200°F (-200 to 650°C).

**Input:** Pt100 RTD and J/K type thermocouple.

**Output:** 16A @ 250 VAC SPDT relay (max current allowed is 10A).

**Control Type:** On/off.

**Power Requirements:** 12 to 24 VAC/VDC, 115 VAC or 230 VAC (depending on model).

**Accuracy:** ±1% F.S.

**Display:** 3-1/2 digit red display.

**Resolution:** 0.1°C.

**Memory Backup:** Non-volatile memory.

**Temperature Limits:** 32 to 131°F (0 to 55°C).

**Weight:** 2.3 oz (65 g).

**Front Panel Rating:** IP 65.

**Agency Approvals:** UL, CE.

**ADJUSTING PARAMETER VALUES**

In order to change the parameter values, follow the procedure below:

- Press UP ARROW and DOWN ARROW simultaneously for four seconds until PA is displayed
- Press SET
- Use UP ARROW or DOWN ARROW to adjust value to -19
- Press SET
- Press UP ARROW and DOWN ARROW simultaneously for four seconds until SP is displayed
- Use UP ARROW or DOWN ARROW to cycle through parameters
- Press SET to view value of parameter
- Use UP ARROW or DOWN ARROW to adjust value of parameter
- Press SET to store value
- Press UP ARROW and DOWN ARROW simultaneously for four seconds to exit menu

**PARAMETER LIST**

Parameter	Description	Units	Range	Factory Setting
SP	Set point	Degrees	r1 to r2	0.0
CA1	Ambient probe adjustment	Degrees	-25 to 25	0.0
P0	Type of input probe	Option	0 to 3	0
P1	Decimal point position	Option	0 or 1	1
P2	Display units	Option	0 or 1	0
P5	Value displayed during normal operation	Option	0 or 1	0
r0	Set point differential	Degrees	0.1 to 99.0	2.0
r1	Minimum set point value	Degrees	-199.0 to r2	0.0
r2	Maximum set point value	Degrees	r1 to 1999	350.0
r3	Set point locked	Option	0 or 1	0
r5	Cooling or heating	Option	0 or 1	1
C1	Minimum time between compressor starts	Minutes	0 to 240	0
C2	Minimum compressor stoppage time	Minutes	0 to 240	0
C3	Minimum on time of compressor	Seconds	0 to 240	0
C4	Off time of fault cycle	Minutes	0 to 240	10
C5	On time of fault cycle	Minutes	0 to 240	10
d0	Interval between defrost	Hours	0 to 99	8
d3	Duration of defrost cycle	Minutes	0 to 99	0
d4	Defrost on power up	Option	0 or 1	1
d5	Defrost delay upon power up	Minutes	0 to 99	0
d6	Display during defrost cycle	Option	0 or 1	1
A1	Alarm set point 1	Degrees	-199 to 1999	0.0
A2	Alarm delay for A1	Minutes	0 to 240	0
A3	Alarm 1 type	Option	0 to 4	0
A4	Alarm delay upon set point modification	Minutes	0 to 240	0
A5	Alarm set point 2	Degrees	-199 to 1999	0.0
A6	Alarm delay for A2	Minutes	0 to 240	0
A7	Alarm 2 type	Option	0 to 4	0
E9	Reserved for future use	None	None	None

**PARAMETER DESCRIPTION**

SP	Sets ambient temperature set point between r1 and r2
CA1	Ambient probe calibration adjustment
P0	Type of input probe 0 = J type thermocouple 1 = K type thermocouple 2 = 3 wire Pt100 RTD 3 = 2 wire Pt100 RTD
P1	Position of decimal place
P2	Display engineering units 0 = °C 1 = °F 2 = No units
P5	Value shown during normal operation 0 = Probe temperature 1 = Set point
r0	Set point differential or hysteresis
r1	Minimum value for set point
r2	Maximum value for set point
r3	Set point lock out 0 = Unlocked 1 = Locked
r5	Selection of heating/cooling operation 0 = Cooling 1 = Heating
C1	Minimum time between compressor starts
C2	Minimum time compressor must remain off before being restarted
C3	Minimum time compressor must remain on after being started
C4	During probe error, time compressor is off
C5	During probe error, time compressor is on
d0	Interval of time between defrost cycles (if 0, defrost will never be activated)
d3	Duration of defrost cycle
d4	Start defrost cycle upon power up 0 = No 1 = Yes
d5	Defrost delay time upon power up (d4 must be 1)
d6	Temperature shown during defrost 0 = Display probe temperature 1 = Display probe temperature up to (set point + r0) if probe temperature is below (set point + r0) at activation of defrost cycle. Display probe temperature if the probe temperature is above (set point + r0) at activation of defrost cycle.
A1	Alarm 1 temperature set point
A2	Alarm 1 not activated unless temperature remains in alarm state for this time
A3	Alarm 1 type 0 = Alarm disabled 1 = Absolute low alarm (A1) 2 = Absolute high alarm (A1) 3 = Deviation low alarm (SP - A1) 4 = Deviation high alarm (SP + A1)
A4	Temperature alarms not activated for this time after modifications to set point
A5	Alarm 2 temperature set point
A6	Alarm 2 not activated unless temperature remains in alarm state for this time
A7	Alarm 2 type 0 = Alarm disabled 1 = Absolute low alarm (A1) 2 = Absolute high alarm (A1) 3 = Deviation low alarm (SP - A1) 4 = Deviation high alarm (SP + A1)
E9	Reserved

**RESISTANCE VS TEMPERATURE TABLE**

Temperature		Resistance Curves (in Ohms)					
°C	°F	A	B	C	D	E	F
-55	-67.0	607800.00	963849.00	289154.70	78.32	783.2	2394000.00
-50	-58.0	441200.00	670166.00	201049.80	80.31	803.1	1646200.00
-45	-49.0	323600.00	471985.00	141595.50	82.29	822.9	1145800.00
-40	-40.0	239700.00	336479.00	100943.70	84.27	842.7	806800.00
-35	-31.0	179200.00	242681.00	72804.30	86.25	862.5	574400.00
-30	-22.0	135200.00	176974.00	53092.20	88.22	882.2	413400.00
-25	-13.0	102900.00	130421.00	39126.30	90.19	901.9	300400.00
-20	-4.0	78910.00	97081.00	29.124.30	92.16	921.6	220600.00
-15	5.0	61020.00	72957.00	21887.10	94.12	941.2	163.500.00
-10	14.0	47540.00	55329.00	16598.70	96.09	960.9	122280.00
-5	23.0	37310.00	42327.00	12698.10	98.04	980.4	92240.00
0	32.0	29490.00	32650.00	9795.00	100.00	1000.0	70160.00
5	41.0	23460.00	25392.00	7617.60	101.95	1019.5	53780.00
10	50.0	18780.00	19901.00	5970.30	103.90	1039.0	41560.00
15	59.0	15130.00	15712.00	4713.60	105.85	1058.5	32340.00
20	68.0	12260.00	12493.00	3747.90	107.79	1077.9	25360.00
25	77.0	10000.00	10000.00	3000.00	109.74	1097.4	20000.00
30	86.0	8194.00	8057.00	2417.10	111.67	1116.7	15892.00
35	95.0	6752.00	6531.00	1959.30	113.61	1136.1	12704.00
40	104.0	5592.00	5326.00	1597.80	115.54	1155.4	10216.00
45	113.0	4655.00	4368.00	1310.40	117.47	1174.7	8264.00
50	122.0	3893.00	3602.00	1080.60	119.40	1194.0	6722.00
55	131.0	3271.00	2986.00	895.80	121.32	1213.2	5498.00
60	140.0	2760.00	2488.00	746.40	123.24	1232.4	4520.00
65	149.0	2339.00	2083.00	624.90	125.16	1251.6	3734.00
70	158.0	1990.00	1752.00	525.60	127.08	1270.8	3100.00
75	167.0	1700.00	1480.00	444.00	128.99	1289.9	2586.00
80	176.0	1458.00	1255.00	376.50	130.90	1309.0	2166.00
85	185.0	1255.00	1070.00	321.00	132.80	1328.0	1822.60
90	194.0	1084.00	915.50	274.65	134.71	1347.1	1540.00
95	203.0	939.30	786.60	235.98	136.61	1366.1	1306.40
100	212.0	816.80	678.60	203.58	138.51	1385.1	1112.60
105	221.0	712.60	587.60	176.28	140.40	1404.0	951.00
110	230.0	623.60	510.60	153.18	142.29	1422.9	815.80
115	239.0	547.30	445.30	133.59	144.18	1441.8	702.20
120	248.0	481.80	389.60	116.88	146.07	1460.7	606.40
125	257.0	425.30	341.90	102.57	147.95	1479.5	525.60
130	266.0	376.40	301.00	90.30	149.83	1498.3	N/A
135	275.0	334.00	265.80	79.74	151.71	1517.1	N/A
140	284.0	297.20	235.30	70.59	153.58	1535.8	N/A
145	293.0	265.10	208.90	62.67	155.46	1554.6	N/A
150	302.0	237.00	186.10	55.83	157.33	1573.3	N/A