

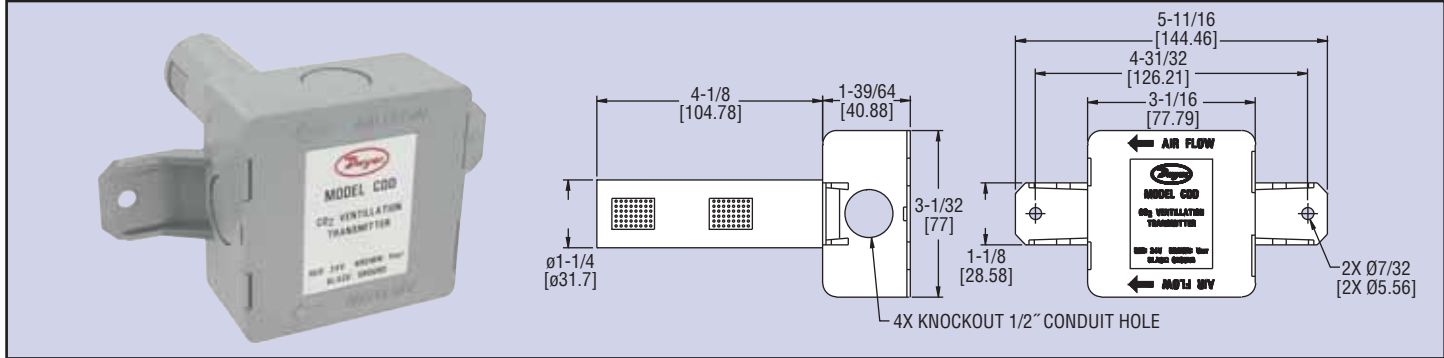

Model  
CDD

# Duct Mount Carbon Dioxide Transmitter

NDIR Sensing Technology, 2000 PPM Range



The Model CDD Duct Mount Carbon Dioxide Transmitter monitors the occupancy in a room by detecting the concentration of carbon dioxide in the return air duct. The non-dispersive infrared sensing technology automatically updates the calibration of the transmitter using a proprietary logic feature which limits the amount of error due to drift. The Model CDD can measure up to 2000 PPM in duct air flows less than 1500 FPM.

Model CDD, Carbon Dioxide Transmitter

## SPECIFICATIONS

**Range:** 0 to 2000 PPM.

**Accuracy:**  $\pm 40$  PPM + 3% of reading @ 22°C.

**Temperature Dependence:** 0.2% FS per °C.

**Stability:** < 2% of FS over life of sensor.

**Non-Linearity:** < 1% of FS.

**Pressure Dependence:** 0.13% of reading per mm of Hg.

**Response Time:** 3 minutes typical for 90% step change.

**Duct Air Velocity Range:** 0 to 1500 FPM (7.63 m/s).

**Ambient Operating Temperature:** 32 to 122°F (0 to 50°C).

**Storage Temperature:** -4 to 158°F (-20 to 70°C).

**Power Requirements:** 18 to 30 VAC RMS 50/60 Hz or 18 to 42 VDC.

**Power Consumption:** 1.65 watts peak (0.65 watts average at 42 VDC).

**Outputs:** 0 to 10 VDC.

**Housing:** Flammability Classification UL rated 94V-5.

**Weight:** 8 oz (230 g).