

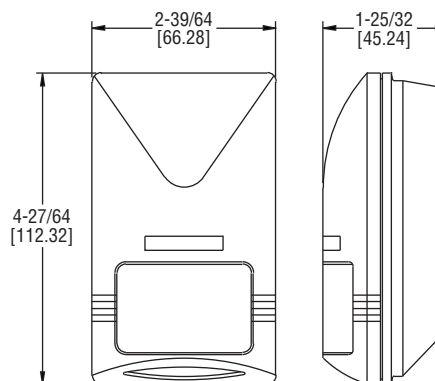



Model OSW-100 Wall Mount Occupancy Sensor

Specifications - Installation and Operating Instructions



The Model OSW-100 Wall Mount Occupancy Sensor is an infrared sensor designed to automatically control a HVAC ventilation system. A unique dual delay processor eliminates false triggers due to short-term occupancies. The Model OSW-100 has a wide 110° viewing angle to capture movement up to 49.2 ft (15 m) away.

INSTALLATION

-  Do not install where the detector is exposed to direct sunlight or directly above strong sources of heat.
-  Do not install in areas that have any obstruction (plants, large pieces of furniture, curtains, etc.) which may block the detection.

SPECIFICATIONS

Infrared Sensor: Dual Element.

Range: 49.2 ft (15 m).

Detectable Speed: 0.33 to 9.8 ft/sec (0.1 to 3.0 m/sec).

Control Output Rating: SPDT, 0.2A @ 30 VDC.

Ambient Operating Temperature: -4 to 140°F (-20 to 60°C).

Power Consumption: Standby: 5 mA, Operating: 18 mA.

Mounting Height: 5.9 to 11.8 ft (1.8 to 3.6 m).

Power Requirements: 22 to 26 VAC/DC.

Weight: 3.2 oz (90.7 g).

Agency Approvals: CE.

MOUNTING

The OSW-100 is designed to be mounted to a wall or corner.

Step 1: Install Base Unit

- Determine the location of the sensor according to the detection pattern shown in Figure 1.
- Screw the base of the mounting bracket to the desired position on the wall as shown in Figure 2.
- Feed the cable through the hole on the back of the bracket.
- Loosen the screw on the bottom of the sensor and remove the cover.
- Feed the cable through the center hole on the back of the sensor housing.
- Attach the sensor to the mounting bracket.

Top view

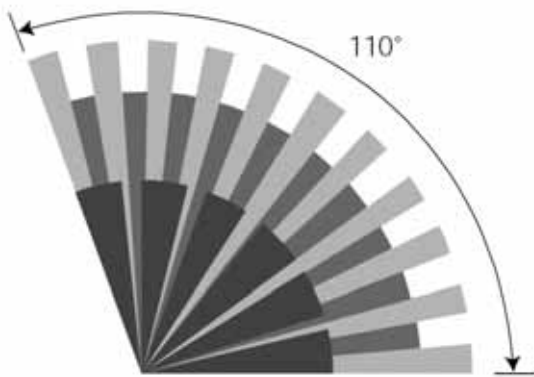

Side view

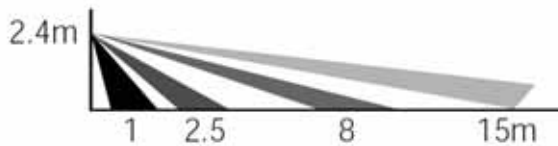

Figure 1
Determining the Location of the Sensor

CEILING MOUNT



WALL MOUNT

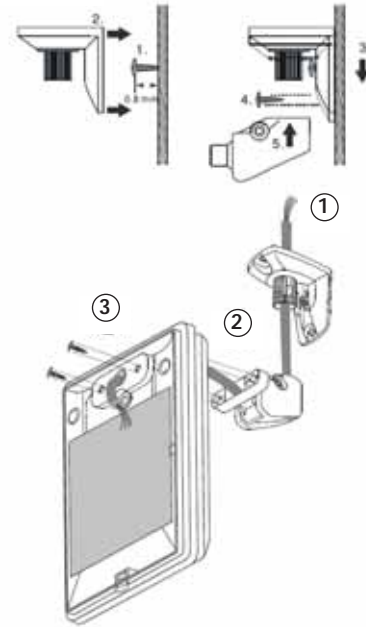
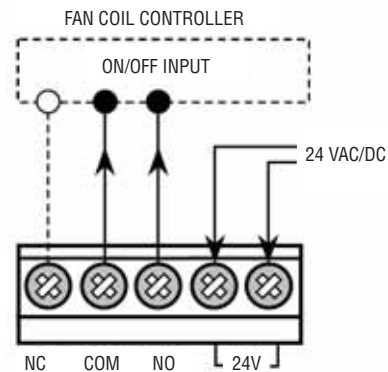

Figure 2
Mounting the Sensor

Step 2: Wiring

- Turn the screw for each terminal counterclockwise.
- Connect the cable to the corresponding terminals as shown in Figure 3.



• **NC-COM-NO:**
Output for ON-OFF control of fan coil operation. Dry contact signal.

• **24V:** Power Supply (non-polarity)

Figure 3
Wiring the Sensor

Step 3: Walk Test

Before beginning test, make certain that the On and Off delay jumpers (located on the circuit board) are connected in the "A" positions as shown in Figure 4. If they are not, follow the procedure under the section titled On/Off Delay Settings to rearrange the jumpers to location "A." Replace the sensor housing and tighten screw.

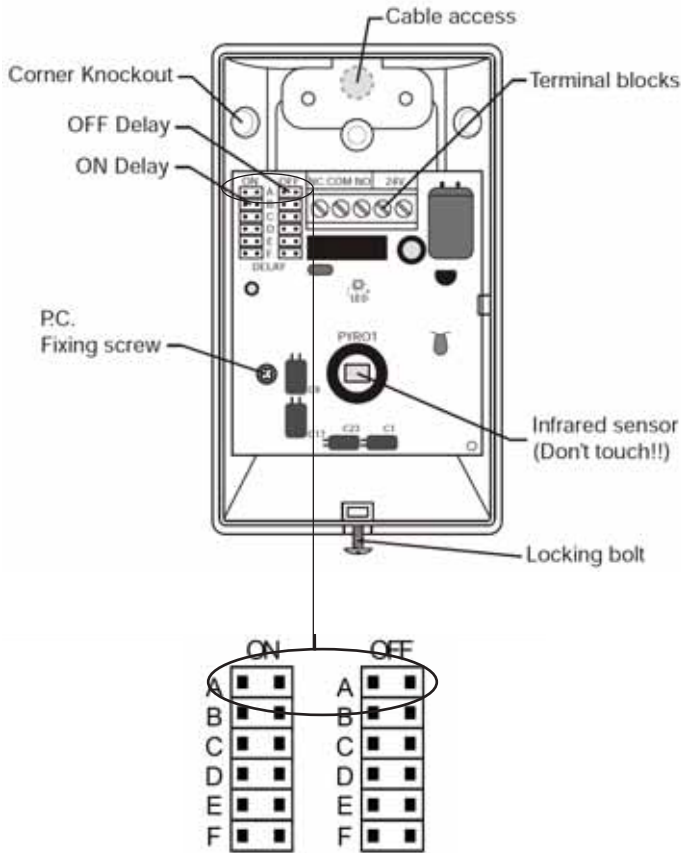

Figure 4

The walk test is used to quickly ensure correct system wiring, proper functioning of the output, and proper orientation/location of the sensor.

- Apply power to the unit and allow 45 seconds for the sensor to warm up. The LED will blink (long blink followed by short) during warm up.

NOTICE

The LED will blink rapidly if the sensor is improperly wired.

- When the LED stops blinking, the sensor has had adequate time to warm up and is now in standby mode (Standby mode is discussed in more detail in the Operation Mode Section.)

- Walk across the detection zone. The LED will stay lit and the output will be activated during occupancy detection.

ON/OFF DELAY SETTINGS

To adjust the On/Off Delay time intervals or adjust sensor for "Walk Test."

1. Remove the cover from the sensor.
2. Refer back to Figure 4 to locate the ON/OFF Delay pins and jumpers on the circuit board.
3. Gently remove the jumpers and reinsert into the desired pins according to the table below.

	A (Walk Test)	B	C	D	E	F
ON	0 Sec.	10 Sec.	30 Sec.	1 Min.	5 Min.	10 Min.
OFF	10 Sec.	1 Min.	5 Min.	10 Min.	20 Min.	30 Min.

4. Replace cover and screw.

Range Adjustment

After installation, the sensor can be manually adjusted to meet the detection needs of a room.

- Loosen the screw on the mounting bracket and then carefully move the unit to the desired direction.
- Refer back to the diagram in Figure 1 and adjust the sensor accordingly.
- Once the sensor is orientated in the desired direction, hold the unit in place and tighten the screw.

OPERATION MODES

The OSW-100 Wall Mount Occupancy Sensor utilizes several operation modes to eliminate false readings and conserve energy.

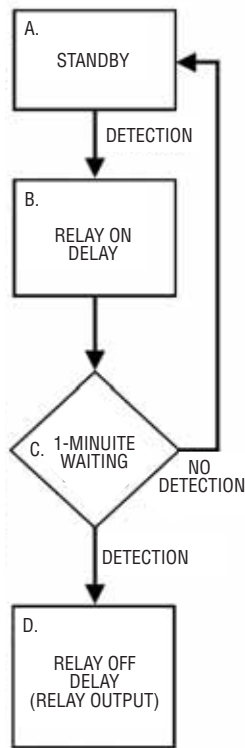

Figure 5

Standby Mode

Before any movement is being sensed, the sensor is in standby mode.

When the sensor detects occupancy, the LED light turns on and the sensor switches to Relay On Delay Mode.

Relay On Delay Mode

This adjustable mode allows the user to choose the time delay before the unit reports that a space is occupied.

The Relay On Delay Mode allows for energy conservation by bypassing short-term or faulty occupancies. It is followed by a secondary one minute warning delay.

1-Minute Warning Mode

During this mode, the sensor searches for any movement for one minute past the Relay On Delay Mode.

If occupancy is detected at any point within that one minute, the output device is activated and the sensor enters Relay Off Delay Mode.

If occupancy is not detected in that one-minute time frame, the sensor enters back into standby mode.

Relay Off Delay Mode

During this mode, the sensor's output is activated for a preset period of time.

Once this preset time interval is up, the output device powers off. However, the relay off delay timer will reset with each motion detection.

This Relay Off Delay Mode allows for energy conservation by eliminating unnecessary running of the HVAC system.

NOTICE

Occupancy detection may be affected if the unit is operated within radio frequency electromagnetic field strength of approximately 3 volts per meter, but the performance of the instrument will not be permanently affected.

Storage and Cleaning

The sensor lens is the most delicate part of the Occupancy Sensor. The lens should be kept clean at all times, care should be taken when cleaning the lens using only a soft cloth or cotton swab with water or medical alcohol. Allow the lens to fully dry before using the sensor. The sensor should be installed or stored in an area of room temperature between -4 and 140°F (-20 to 60°C).

MAINTENANCE

After final installation of the unit, no routine maintenance is required. The Model OSW-100 is not field serviceable and should be returned if repair is needed (field repair should not be attempted and may void warranty). Be sure to include a brief description of the problem plus any relevant application notes. Contact customer service to receive a return goods authorization number before shipping.